

## Medical Terminal Unit - Gem Shield

### DIN 13260-2

#### SPECIFICATION

##### Medical Terminal Unit (Gem Shield DIN)

Medical terminal units are located at the final delivery points in medical gas piping systems to provide quick connection to the system. Terminal units provide for single handed insertion and removal of the medical gas probe.

Terminal units are Class IIb medical devices with the CE mark, built to comply with European Directive 93/42/EC governing medical devices to ensure non-interchangeability among different gasses. Terminal units conform to gas specific dimensions and connection requirements stated in DIN 13260-2. Components are designed and manufactured in accordance with BS EN ISO 9170 for medical gas distribution systems.

Medical gas terminal units consist of two parts:

First fix – the wall mounted assembly consists of brass pipeline termination block with copper stub pipe secured between a back plate and a gas specific plate to allow 130 degrees radial movement of the copper stub to align with the pipeline.

The second fix plastic components shall be manufactured with the pin index permanently moulded into the gas specific socket. The socket assembly shall retain a capsule assembly, containing the check valve and probe 'O' ring seals. Second fix terminal units shall be supplied with the anti-rotation pin loose and bagged to be fitted as required.

The socket is fixed to the base block with a design that insure profile is always in the correct position.

Probes are gas specific connectors that couple to the medical gas terminal unit sockets to provide access to gas systems.

The replaceable capsule assembly shall enable all working parts subject to wear through usage to be replaced as a factory tested assembly, thereby reducing maintenance time. Each termination block assembly shall be pressure tested by the pressure decay method.

##### Gas Specificity

Terminal units shall be gas specific and only accept the correct medical gas probe. Gas specific components shall be pin-indexed to ensure that a correct gas specific assembly is achieved so that in normal course of dismantling for repair or maintenance, parts from other gases cannot inadvertently be used. Wall mounted and bedhead terminal units shall incorporate an anti-rotation pin to engage with connected downstream medical equipment ensuring correct orientation.

##### Materials

All screws, probe roller pins, locking springs and the anti-rotation pin shall be manufactured from stainless steel. The second fix assembly shall incorporate three injection moulded parts in fire-retardant nylon 66. All wetted parts (except seals) shall be brass or copper. Copper stubs pipes shall be manufactured from phosphorous de-oxidised non-arsenical copper to BS EN 1412 grade CW024A, manufactured to metric outside diameters in accordance with BS EN 13348 R250 (half hard). All elastomeric seals shall be manufactured from Viton with a Shore hardness of 75.

##### Antimicrobial Additive

All user accessible parts, 2<sup>nd</sup> fix, gas ID ring, plaster box, trim plate and inks shall include Biomaster silver ion antimicrobial additive for inherent antimicrobial protection. Verimaster additive shall also be included to enable the end user to verify the product is a genuine BeaconMedæS product.

\* Biomaster and Verimaster are registered products of Addmaster (UK).

Sample	Species	Reduction
Gas ID Ring	E coli	≥ 99.77%
Gas ID Ring	MRSA	≥ 99.82%
Trim Plate	E coli	≥ 99.92%
Trim Plate	MRSA	≥ 99.93%
Plaster Box	E coli	≥ 99.94%
Plaster Box	MRSA	≥ 99.35%

\* Determination of antimicrobial activity using test based on ISO 22196 Plastics - Measurement of anti bacterial activity on plastics surfaces.

##### Pipeline Connections

Terminal units installed in walls, bedhead trunking, headwalls or fixed pendants shall be connected to the pipeline with a copper stub pipe. Pressure gases and vacuum shall incorporate a 12mm O/D copper stub pipe. Terminal units for anaesthetic gas scavenging shall incorporate a 15mm O/D copper stub pipe.

Terminal units installed in booms or moveable pendants shall be attached to their respective flexible gas hose by a gas specific non-interchangeable screw thread (NIST) fitting to BS EN ISO 5359. Terminal units shall be fitted with a male NIST and nut for connection to hoses with a female NIST connection.

##### Performance

Pressure drops across the terminal unit shall comply with clause 4.4.11 of BS EN ISO 9170-1. The flow/pressure drop characteristics for the Gem terminal unit are shown below with the maximum allowable value.

Nominal pressure (kPa)	Test pressure (kPa)	Flow (l/min)	EN 9170-1 limit (kPa)	Gem 10 (kPa)
400-500	320	40	15	0.6
400-500	320	200	70	14
700-10000	560	350	70	30
Vacuum	*40	25	15	1.1

\* Absolute pressure

##### CE Marking

The standard range of BeaconMedæS Gem Medical Gas Terminal Units and Gem Conversions are 'CE' marked under the Medical Devices Directive 93/42/EEC with approval from notified body no. 2460 ( DNV GL Presafe AS). Under this directive, the specified products are classified as Class IIa Medical Devices.

##### Warranty

The terminal units shall have a three-year warranty, subject to the recommended minimum routine maintenance operations being carried out by correctly competent persons.



**Gem Shield DIN Terminal Unit. First Fix Installation Dimensions DIN13260-2**

First fix "Revolve"

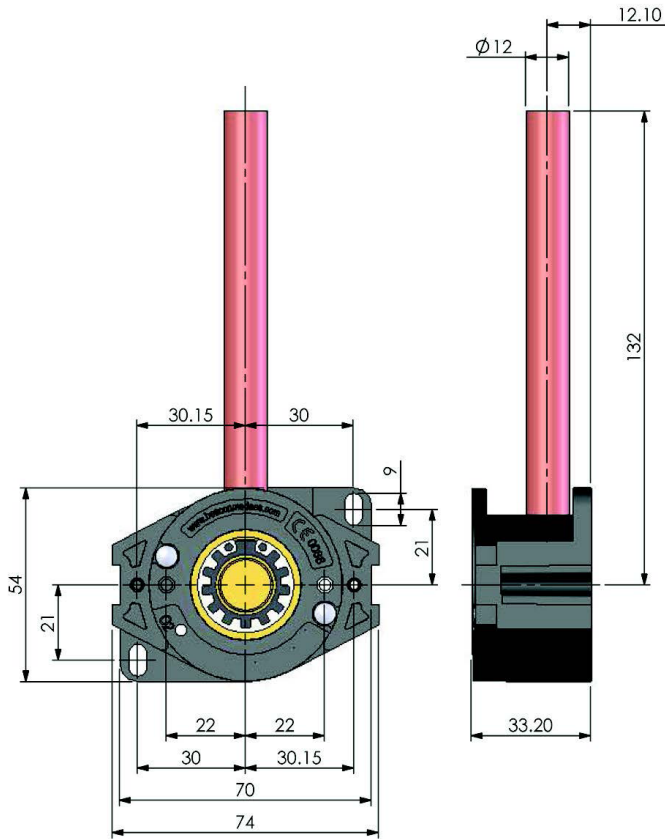

First fix "Revolve"

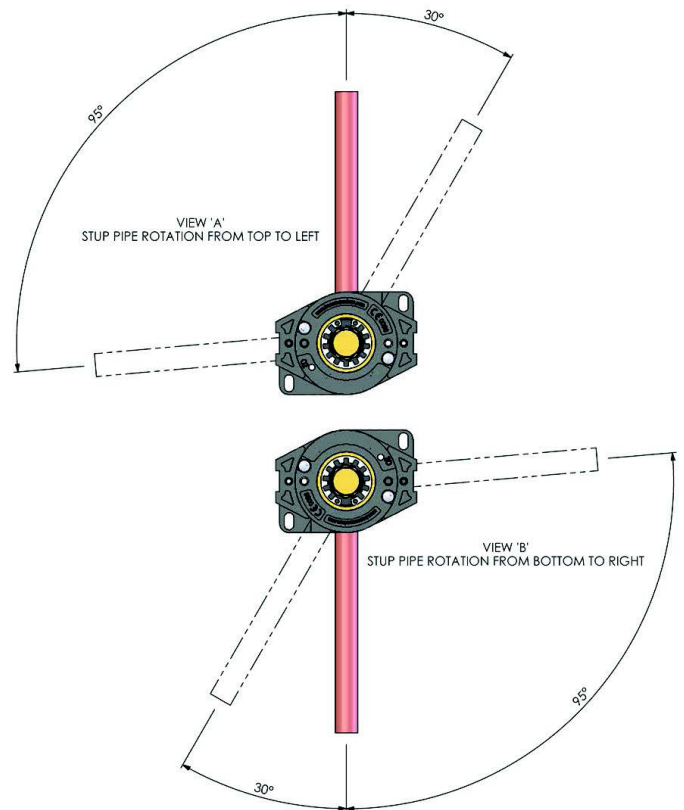

Gas	1 <sup>st</sup> fix Mod/Wall
O <sub>2</sub>	8102340210
N <sub>2</sub> O	8102340211
N <sub>2</sub> O/O <sub>2</sub>	8102340212
MA	8102340213
SA <sup>4</sup>	8102340214
VAC	8102340215
N <sub>2</sub>	8102340216
CO <sub>2</sub>	8102340217
AGSS <sup>4</sup>	8102340218

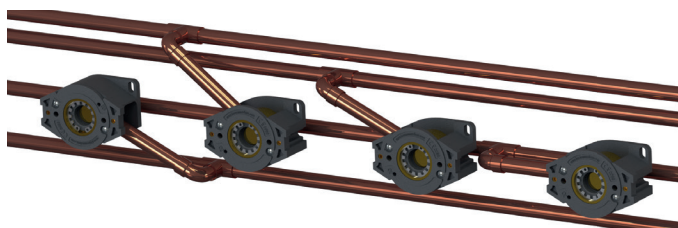

Typical example of pipe arrangement for trunking systems

**Notes:**

1. Backplate includes two slotted fixing holes (bottom) in order to provide adjustment of the terminal within the bedhead unit.
2. First fix "Revolve" type is identical for BS5682 and DIN 13260-2 standard.
3. Gem Shield 2nd fix does not require disassembling during installation due to the fastener access points.
4. In a standard DIN 13260-2 Air-800 and AGSS are not defined. If using BS5682 standard AIR-800 and/or AGS, use the following part numbers.



**Gem Shield DIN Terminal Unit. Second Fix**

Gas	2 <sup>nd</sup> fix
O <sub>2</sub>	8102371370
N <sub>2</sub> O	8102371371
MA	8102371372
VAC	8102371373
N <sub>2</sub>	8102371374
CO <sub>2</sub>	8102371375

**Second Fix Gem Shield Stainless steel. Thread Connection**

Gas	2 <sup>nd</sup> fix
AGSS <sup>1</sup>	8102340208
N <sub>2</sub>	8102340206
CO <sub>2</sub>	8102340207



## Notes:

1. AGSS according to ISO 9170-2 type 1L see page #4.
2. In a standard DN 13260-2 terminal unit connections for Air-800 and AGSS are not defined. If using BS5682 standard, use the following part numbers.
3. First fix "Revolve" is identical for BS5682 and DIN 13260-2 standard.

### Range of First fixes

There are many possible terminal unit configurations types available on request to suit almost any applications.

Gas	Mod/Wall, 150 mm	Straight stub, 1,700 mm	Pendant Rear NIST	Retractable Pendant	Flexible Pendant <sup>1</sup>
O <sub>2</sub>	8102340210	8102340980	8102369860	8102369870	8102340450
N <sub>2</sub> O	8102340211	8102340981	8102369861	8102369871	8102340451
N <sub>2</sub> O/O <sub>2</sub>	8102340212	8102340982	8102369862	8102369872	n.d.
MA	8102340213	8102340983	8102369863	8102369873	8102340452
SA <sup>2</sup>	8102344210	8102340984	8102369864	8102369874	8102340284
VAC	8102340215	8102340985	8102369865	8102369875	8102340453
N <sub>2</sub>	8102340216	8102340986	8102369866	8102369876	8102340454
CO <sub>2</sub>	8102340217	8102340987	8102369867	8102369877	8102340455
AGSS <sup>2</sup>	8102340218	8102340988	8102369868	8102369878	8102340288

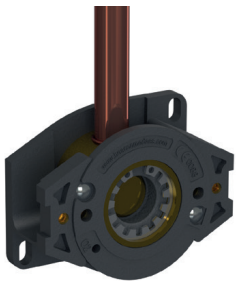

Modular/Wall. Straight stub

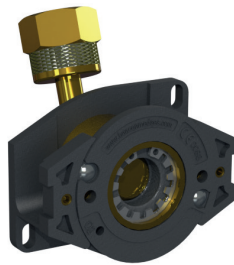

Pendant Rear NIST

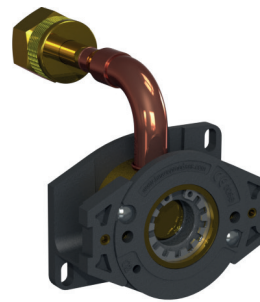

Retractable Pendant



Flexible Pendant

Gas	Hose Barb <sup>2</sup>	Rigid Pendant, 1,500mm	Curved, 150mm	Rear Stub, 150mm	Rear Stub, 1,400mm
O <sub>2</sub>	8102369890	8102369880	8102340230	8102341570	8102341540
N <sub>2</sub> O	8102369891	8102369881	8102340231	8102341571	8102341541
N <sub>2</sub> O/O <sub>2</sub>	8102369892	8102369882	8102340232	8102341572	8102341542
MA	8102369893	8102369883	8102340233	8102341573	8102341543
SA <sup>2</sup>	8102369894	8102369884	8102340234	8102341574	8102341544
VAC	8102369895	8102369885	8102340235	8102341575	8102341545
N <sub>2</sub>	8102369896	8102369886	8102340236	8102341576	8102341546
CO <sub>2</sub>	8102369897	8102369887	8102340237	8102341577	8102341547
AGSS <sup>2</sup>		8102369888	8102340238	8102341578	8102341548

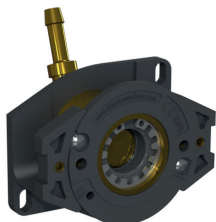

Hose Barb

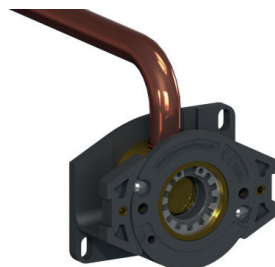

Rigid Pendant

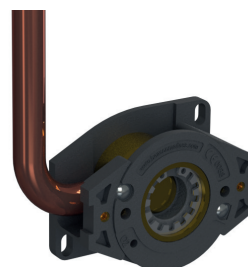

Curved



Rear Stub

Notes:

1. Flexible pendant supplied complete: first+second fix. Shroud supplied with hose assembly.
2. In a standard DIN 13260-2 Air-800 and AGSS are not defined. If using BS5682 standard AIR-800 and/or AGS, use the following part numbers.
3. There are many possible terminal unit configurations types available on request to suit almost any application. Typical examples are barbed hose connection, DISS connection, vertical NIST.



**AGSS Terminal Unit Type 1L ISO 9170-2**

Part Number	Description
8102340968	Complete AGSS Type 1L Terminal Unit for centralized system (VEGS120/EN1)
4107205662	Active Terminal Unit Type 1L
4107205663	Active Terminal Unit Type 1L with fixing disk
4107205777	Mounting Box for AGSS active terminal unit Type 1L
4107205754	AGSS probe, EN ISO 9170-2. 60° Barb end. Type 1L

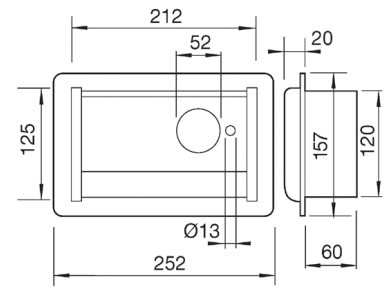

Mounting Box for Active Socket

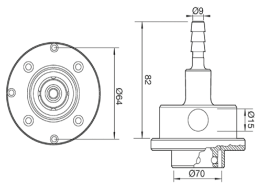

Terminal unit for Pendant

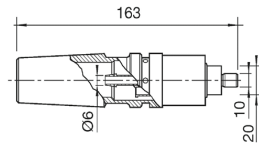

Probe Air Motor

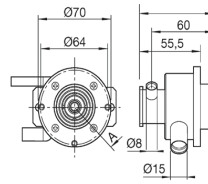

Terminal Unit

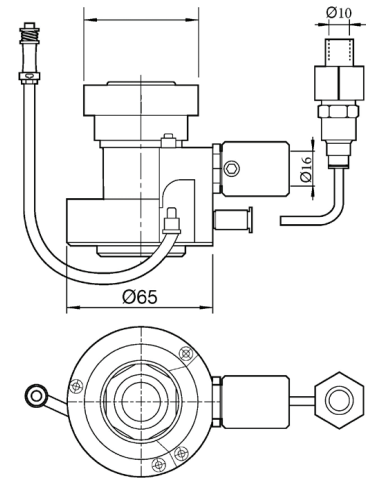

Active Terminal Unit AGSS type 1L

**Air Motor Terminal Unit & Probe ENV 737-6**

Part Number	Description
4107205756	Air motor terminal unit for pendant
4107205758	Air motor terminal unit
4107205757	Air Motor probe

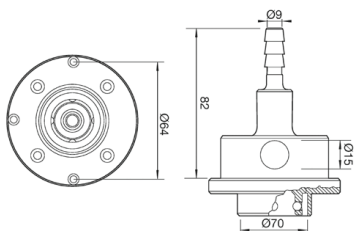

Terminal unit for Pendant

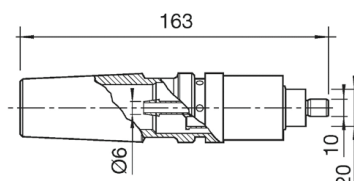

Probe Air Motor

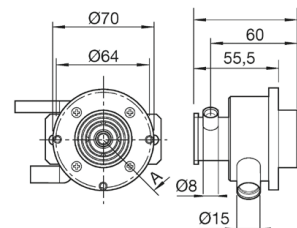

Terminal Unit

**Hose assemblies to suit GEM pendant outlets**

Gas	BS 5682: NIST hose assembly (Male/Female)
O <sub>2</sub>	42331120xx
N <sub>2</sub> O	42331121xx
N <sub>2</sub> O/O <sub>2</sub>	42331122xx
MA	42331123xx
SA	42331124xx
VAC	42331125xx
AGS	42331126xx
N <sub>2</sub>	42331128xx
CO <sub>2</sub>	42331129xx
Gas	BS 5682: NIST hose assembly (Male/Female) Complete with Shroud
O <sub>2</sub>	42331170xx
N <sub>2</sub> O	42331171xx
N <sub>2</sub> O/O <sub>2</sub>	42331172xx
MA	42331173xx
SA	42331174xx
VAC	42331175xx

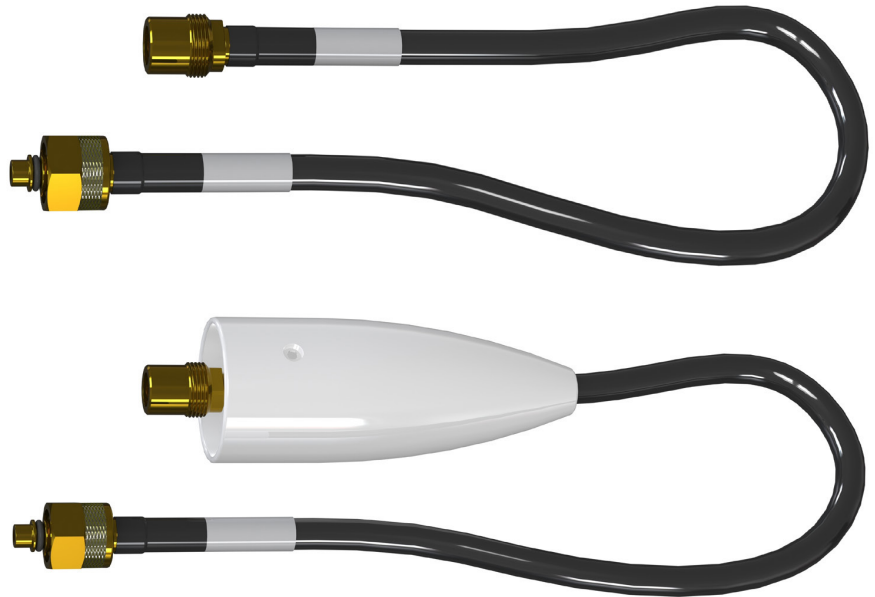

## Notes:

 1. The final 2 digits shown as 'xx' in the tables above denote the hose length in meters. i.e. a 1.5 meter long O<sub>2</sub> hose would be 4233112015

**Probe Connection**

Gas	Elbow Barb End	Elbow barb end with Check Valve	H
Oxygen	4107205687	4107205704	6
Vacuum	4107205691	n.a.	8
Air	4107205688	4107205705	6
Nitrous oxide	4107205689	4107205706	6
Carbon dioxide	4107205690	4107205707	6

## Note:

 N<sub>2</sub> probe with check valve is not defined.

Elbow Barb End

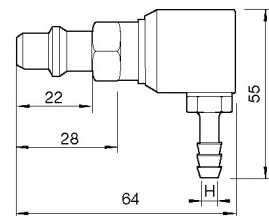

Elbow barb end with Check Valve

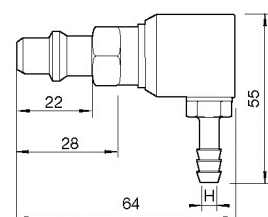

## Accessories

Part Number	Description
8102340127	Gem Plaster Box & Surface Mounting Kit - Gases
	Gem Plaster Box & Surface Mounting Kit - AGS
2006149	Bezel and Trim Plate
8102340179	GEM 1 <sup>st</sup> fix adaptor plate kit
2003381	GEM Grommet (e.g. for trunking)

Size	Jig Plates	Stainless steel trim plate
1 Gas		1826978
2 Gas (150 mm spacing)	8102340521	
2 Gas (133.5 mm spacing)	8102340520	1826979
3 Gas (133.5 mm spacing)	8102340522	1826980
4 Gas (133.5 mm spacing)	8102340523	1826981
5 Gas (133.5 mm spacing)	8102340524	1827026
6 Gas (133.5 mm spacing)	8102340525	1827027

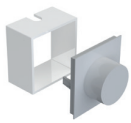

Mounting Box  
Plaster Shield

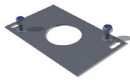

Adaptor plate  
kit



Terminal Unit  
Plug<sup>2</sup>



Bezel and  
Trim Plate Kit

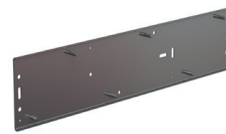

Jig Plates - for accurate  
flush wall mounting

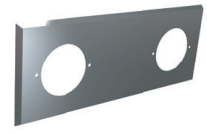

Stainless Steel Trim  
Plate

### Notes:

1. All terminal unit accessories are suitable for use with GemB quick connect or Gem threaded terminal units.
2. Terminal Unit Plug provided with all 1st fix assemblies in order to complete on site 1st fix pipeline carcass testing

## Parts Including Antimicrobial Additive

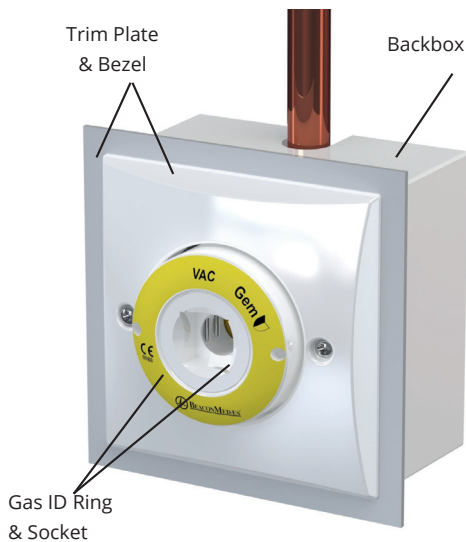

## Terminal Unit Installation / Dimension Drawings

Part Number	Type
8102340219	GEM Revolve 1st fix mod/wall
8102340199	GEM Shield DIN 2nd fix
8102340222	GEM Shield AGS BS 2nd fix
8102340221	GEM Shield CO2 BS 2nd fix
8102340220	GEM Shield N2 BS 2nd fix
8102340459	GEM Shield fl exible/hose assembly
8102340429	GEM Shield Pendant rear NIST
8102340439	GEM Shield Retractable pendant
8102340449	GEM Shield Retractable rigid
8102340979	GEM Shield Barb connection

Drawings detailing different views and all dimensional information are available upon request - please refer to table above. 3D images are available upon request - please contact our technical department.